

AB-100

Announcer's Console

INSTRUCTION MANUAL



Clear-Com[®]
Intercom Systems

4065 Hollis St., Emeryville, CA 94608 (510) 496-6666

Clear-Com Systems

AB-100 ANNOUNCER'S CONSOLE

Instruction Manual

AB-100 Instruction Manual

Second Edition, November, 1994

This revision manual is for units manufactured after November 1, 1994

P/N 810197

(C) 1994 Clear-Com Systems

All Rights Reserved

Clear-Com Intercom Systems

945 Camelia St.

Berkeley, Ca. 94710

U.S.A

Clear-Com is a registered trademark of Lumiere Productions, Inc.

The Clear-Com Logo is a registered trademark of Lumiere Productions, Inc.

RTS is registered trademark of Telex Communications Inc.

Switchcraft is a register trade mark of Switchcraft Inc.

Neurtik is a registered trademark of Neurtik AG.

While Clear-Com makes every attempt to maintain the accuracy of the information contained in its product manuals, that information is subject to change without notice.

| | |
|---|----|
| DESCRIPTION | 1 |
| TECHNICAL SPECIFICATIONS: | 2 |
| MICROPHONE PRE-AMP: | 2 |
| LINE LEVEL OUTPUTS: | 2 |
| HEADPHONE AMPLIFIER: | 2 |
| BALANCED PROGRAM INPUT: | 3 |
| POWERED IFB INPUT: | 3 |
| INTERCOM LINE DRIVE/RECEIVE CIRCUITS: | 3 |
| CONNECTORS: | 3 |
| POWER REQUIREMENTS: | 3 |
| PHYSICAL SPECIFICATIONS: | 3 |
| | |
| INSTALLATION | 4 |
| FACTORY DEFAULT SETUP | 4 |
| TWO MODES OF OPERATION | 4 |
| SPORTSCASTER'S CONSOLE (Momentary Mic Mute) | 4 |
| ANNOUNCER'S CONSOLE (Latching Mic) | 5 |
| SELECTING MICROPHONE AMPLIFIER GAIN | 5 |
| Microphone Preamplifier Gain | 6 |
| Line Output Level Select | 6 |
| OPTIONS FOR POWER | 7 |
| Power From The Intercom Line | 7 |
| Power From The IFB Line | 7 |
| Power From An AC Wall Mount Transformer | 7 |
| DESCRIPTION OF REAR PANEL CONNECTORS AND CONTROLS | 8 |
| Headset Connector | 8 |
| Mic Out Connector | 9 |
| Intercom Line Connectors (XLR-3 male & female): | 10 |
| IFB (XLR-3 female): | 10 |
| Matrix Plus/AUX (Rear Panel, DB-15M) | 11 |
| Viewed from the rear of the connector | 11 |
| DESCRIPTION OF INTERNAL JUMPER OPTIONS AND ADJUSTMENTS | 12 |
| JUMPER OPTIONS | 12 |
| MICROPHONE OUTPUT PAD | 14 |
| DIP SWITCH SELECTION OF EARPHONE OUTPUT | 14 |
| HEADPHONE SIDETONE ADJUSTMENT | 14 |
| APPLICATION OF VARIOUS INTERCOM SYSTEM TYPES | 15 |
| Clear-Com Party-Line | 15 |
| Matrix Plus Digital Intercom Systems | 17 |
| TW Party-Line Systems (RTS) | 20 |
| Other 4-wire Systems | 22 |
| INSTALLATION OF SECOND CHANNEL OPTION PCB | 24 |
| INSTALLATION OF SECOND CHANNEL OPTION BOARD | 25 |

| | |
|---|----|
| OPERATION | 26 |
| SPORTSCASTER MODE | 26 |
| ANNOUNCERS MODE | 27 |
| BILL OF MATERIALS OF MISC. CHASSIS PARTS | 33 |
| BILL OF MATERIALS FOR THE PCB ASY | 33 |
| BILL OF MATERIALS FOR THE 2ND CHANNEL OPTION PCB ASY | 39 |

CLEAR-COM LIMITED WARRANTY

Clear-Com products are warranted to be free from defects in materials and workmanship for a period of one year from the date of sale.

Clear-Com's sole obligation during the warranty period is to provide, without charge, the parts and labor necessary to remedy covered defects appearing in products returned prepaid to Clear-Com, 945 Camelia St., Berkeley, Ca. 94710-1484, U.S.A.

This warranty does not cover any defect, malfunction or failure caused beyond the control of Clear-Com, including unreasonable or negligent operation, abuse, accident, failure to follow instructions in the Manual, defective or improper associated equipment, attempts at modification and repair not authorized by Clear-Com, and shipping damage. Products with their serial numbers removed or defaced are not covered by this warranty.

To obtain warranty service, follow the procedures described below in "Procedures for Returns" and "Shipping to Manufacturer for Repair or Adjustment."

This warranty is the sole and exclusive express warranty given with respect to Clear-Com products. It is the responsibility of the user to determine before purchase that this product is suitable for the user's intended purpose.

Any and all implied warranties, including the implied warranty of merchantability are limited to the duration of this express limited warranty. Neither Clear-Com nor the dealer who sells Clear-Com products is liable for incidental or consequential damages of any kind.

Return Shipping Instructions

Procedures for returns:

- If repair is necessary, contact the dealer where the unit was purchased.
- If repair through the dealer is not possible, contact the Clear-Com Customer Service Department, located at the factory, as directed below. They will issue a Return Authorization Number (RMA).
- Do not return any equipment to the factory without first obtaining a Return Authorization Number.

--Be prepared to provide your company's name, address, phone number, name of person to contact regarding the repair, type and quantity of the equipment, description of the defect, and the equipment serial number(s).

Questions regarding returns for repair should be directed to:

Customer Service Department
Clear-Com Intercom Systems
945 Camelia Street
Berkeley, California 94710-1484
Telephone: (510) 527-6666
Fax: (510) 527-6699

Shipping to Manufacturer for Repair or Adjustment

All shipments of Clear-Com equipment must be prepaid via United Parcel Service or the best available shipper. The equipment should be shipped in the original packing container; however, if the original container is not available, use a suitable container that is rigid and of adequate size. If a substitute container is used, the equipment should be wrapped in paper and surrounded with at least four inches of excelsior or similar shock-absorbing material. A detailed description of the problem or work to be done should be included. All shipments should be directed to the attention of the Customer Service Department and must include the Return Authorization Number.

Upon completion of repairs, equipment will be returned collect via United Parcel Service or other specified shipper.

NOTICE ABOUT SPECIFICATIONS

Performance specifications included in this manual are design-center specifications and are included for customer guidance and to facilitate system installation. Actual operating performance may vary.

BEFORE YOU BEGIN . . .

To get the most out of the AB-100 Announcer's Console, read this manual carefully. It will answer questions you might have about the operation and service of the components in the system. Clear-Com's Customer Service Department is available to answer questions not covered in this manual.

DESCRIPTION

The AB-100 Announcer's Console is a compact desktop unit designed specifically for sports and live event broadcasting. The AB-100 integrates all of the inputs, outputs and controls necessary at the announce position, including intercom "Talkback," IFB, and a "Mute" button.

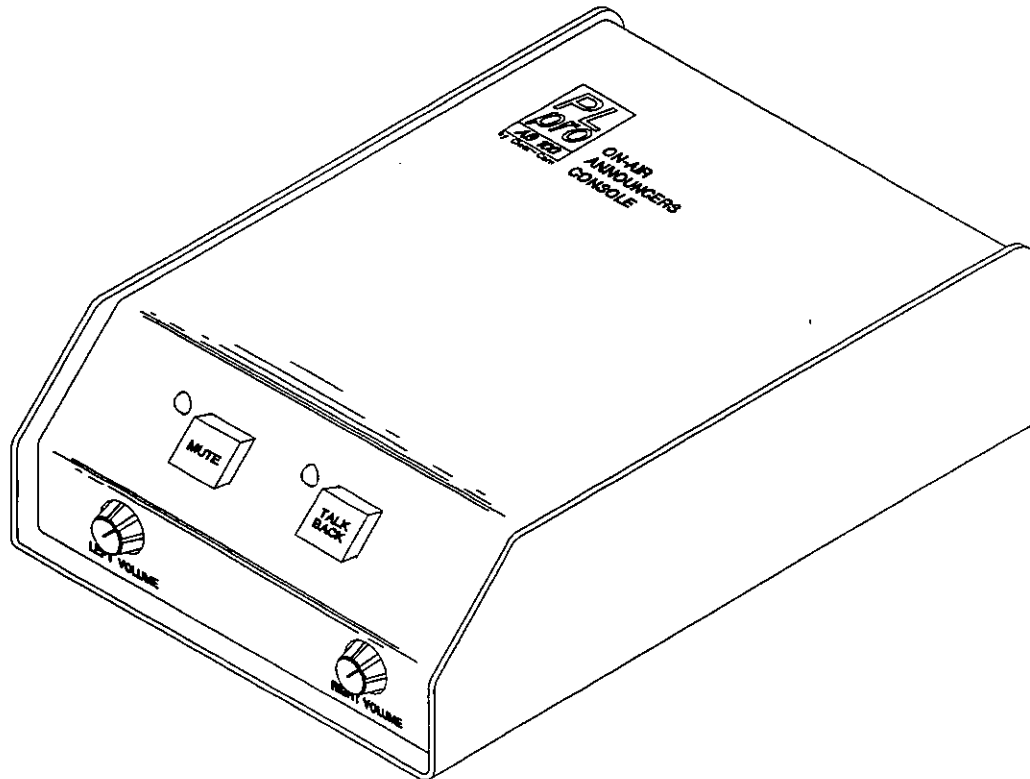

A low-noise, low-distortion balanced microphone preamplifier delivers broadcast-quality sound from the announcer's microphone. The AB-100 can be used with virtually any broadcast headset or separate microphone/headphone. Mic gain is jumper selectable to accommodate all microphone types. The microphone output stage uses a high grade transformer for driving the line. Output levels from 0dB to -50dB are jumper selectable.

A high-output stereo headphone amplifier provides talent with both program audio and "cues" from the control room, even in the loudest of sporting environments. The console can be configured so that intercom audio and IFB inputs can be heard in the left ear, right ear, or both ears, helping the talent to instantly identify the source. The unit accepts one or two channels of IFB, which can be standard balanced audio or self-powered three-pin circuits like those found on most broadcast IFB systems.

Instant access to a intercom system is available with a "Talkback" button. If the Talkback button is pushed, the microphone is momentarily switched from on-air duty to intercom use. The Announcer's Console can be connected to virtually any party-line or 4-wire intercom system. The AB-100 connects directly to Clear-Com party-line and Matrix Plus II digital intercom. A "mute" button (talent cough switch) provides momentary muting of the microphone. Alternately, it can be set to latch when pressed, allowing talent to switch the Mic on and off with a single touch. The switch is mechanically and electrically silent to ensure no clicking or switching noise when pressed.

An optional second channel of Talkback can be installed for TW-type intercom systems. The second channel is activated while the Mute button is pressed.

The AB-100 plugs into and draws power directly from most intercom and IFB systems, permitting an announce position to be located virtually anywhere, regardless of available AC power. When a powered intercom or IFB system is not available, the console can be externally powered with the supplied AC adapter or a DC source.

TECHNICAL SPECIFICATIONS:

MICROPHONE PRE-AMP:

| | | |
|-------------------------------|-------|---------------------------|
| Input Impedance | ----- | 1K Ohms |
| Input Level | ----- | - 55 to -35dBv* |
| Frequency Response | ----- | 100 Hz to 15 KHz, +/- 1dB |
| Electret Drive Voltage Option | ----- | 10 Volts DC Aprox. |
| Condenser Mic Power Option | ----- | 48 VDC Phantom |

LINE LEVEL OUTPUTS:

| | | |
|---------------------|-------|---|
| Type: | ----- | Transformer Balanced |
| Level: | ----- | -10dBV* Nominal (Jumper and Pad Selectable) |
| Impedance: | ----- | To Drive 600 Ohm Line |
| Frequency Response: | ----- | 20Hz -15KHz +/- 1dB |
| Distortion: | ----- | <0.05% THD at 100Hz - 10 KHz |
| Head Room: | ----- | +20dBV* before clipping |

HEADPHONE AMPLIFIER:

| | | |
|--------------------------|-------|-------------------------|
| Load Impedance: | ----- | greater than 8 Ohms |
| Output Level: | ----- | Max 4 Watts into 8 Ohms |
| Distortion: | ----- | <0.2% THD at 1 KHz |
| Frequency Response: | ----- | 100-15KHz +/- 3dB |
| Gain from Intercom Line: | ----- | +37 dB |

BALANCED PROGRAM INPUT:

Type: _____ Transformer Balanced
 Input Level Ref.: _____ -10 dBv*
 Input Impedance: _____ 10 KOhms Bridiging
 Frequency Response: _____ 150 Hz to 15 KHz

POWERED IFB INPUT:

Type: _____ 2 Ch Unbalanced, Transformer
 Isolated
 Input Level Ref.: _____ -10 dBv*
 Input Impedance: _____ 10 KOhms Bridiging
 Frequency Response: _____ 150 Hz to 15 KHz

INTERCOM LINE DRIVE/RECEIVE CIRCUITS:

Impedance, Output Load: _____ > 10 KOhms (200Hz - 10 KHz)
 Level, Line (200 ohm load): _____ -9 dBv* (nominal) +5dBv (max
 before clip)
 Sidetone Null Capability: _____ > 25 dB (150Hz - 15 KHz)

CONNECTORS:

Headset: _____ XLR-6F
 Mic Out: _____ XLR-3M
 Intercom: _____ 2-XLR-3 (Male & Female
 Loop-thru)
 IFB: _____ XLR-3F
 Matrix Plus/AUX: _____ DB-15M
 Power: _____ 2.1 mm Coaxial

POWER REQUIREMENTS:

Intercom/IFB:
 Voltage _____ 25 - 30 VDC
 Current _____ 65 mA idle, 120 mA average
 AC Transformer: (115 VAC)
 Voltage _____ 24 VAC @ 15 VA

PHYSICAL SPECIFICATIONS:

Dimensions: _____ 6"W x 3"H x 8"D
 (152mm x 76mm x 203mm)
 Weight: _____ 2 lbs (0.9 Kg)
 Operating Temperature Range: _____ 32-122° F (0-50° C)

* - 0dBv = 0.775 volts RMS.
 (Specifications subject to change without notice.)

INSTALLATION

The AB-100 is a versatile interconnection box, and as such many types of installations can be accommodated. This section describes the following subjects:

- FACTORY DEFAULT SETUP
- TWO MODES OF OPERATION
- HEADSET CONNECTION
- SELECTING MICROPHONE AMPLIFIER GAIN
- OPTIONS FOR POWER
- DETAIL DESCRIPTION OF CONNECTORS
- DESCRIPTION OF INTERNAL JUMPER OPTIONS AND ADJUSTMENTS
- APPLICATION TO VARIOUS INTERCOM SYSTEM TYPES
- INSTALLATION OF THE SECOND CHANNEL OPTION BOARD

NOTE: There are two versions of the Printed Circuit Board in the AB-100. This manual describes the units manufactured after November 1, 1994 with serial numbers greater than 565428. The two versions are functionally the same. The numbering of the internal jumpers is different.

FACTORY DEFAULT SETUP

As shipped from the factory, the AB-100 has its internal jumpers and dip switches set to implement the Clear-Com Party-Line setup described on page 15 of this manual. The unit is setup for SPORTSCASTER CONSOLE type operation and the Mic Output level is set for -20 dB. The unit will operate on power from the intercom line or from a wall-mounted transformer.

For variations on this factory default setup, read the rest of this chapter on Installation.

TWO MODES OF OPERATION

The logic circuitry of the AB-100 supports two basic modes of operation; Sportscaster's Console and Announcer's Console. The next two sections describe each.

SPORTSCASTER'S CONSOLE (Momentary Mic Mute)

To select the SPORTSCASTER MODE place a jump jack on pins 1 and 2 of JP11.

In the "Sportscaster's Console" mode both front panel buttons are momentary in operation and microphone output is active except when either of the buttons is pressed. The Red Led next to the MUTE (left) button is illuminated whenever the mic output is active.

Pressing the MUTE button turns the output of the microphone circuit off as long as the button is pressed. If the optional second channel of Talkback is installed, it is activated while the Mute button is pressed.

Pressing the TALKBACK (right) button turns the output of the microphone circuit off and sends the microphone signal to the intercom line. The Green Led next to this button is illuminated when the talkback circuit is active.

ANNOUNCER'S CONSOLE (Latching Mic)

To select the ANNOUNCER MODE place a jump jack on pins 2 and 3 of JP11.

In the "Announcer's" mode the MIC ON/OFF (left) button is latching in action and the TALKBACK (right) button is momentary in action. The Red Led next to the MIC ON/OFF button is illuminated whenever the mic output is active.

Pressing the MIC ON/OFF button toggles the state of the mic from On to OFF or from OFF to ON each time the button is pressed. NOTE: In the ANNOUNCER MODE use of the second talkback channel is not recommended. There is no indication when the second channel talkback is active. If the second talkback channel is used it is active only while the MIC ON/OFF button is pressed. Its active state does not follow the RED LED.

Pressing the TALKBACK (right) button turns the output of the microphone circuit off, resets the MIC ON/OFF latch to the OFF condition, and sends the microphone signal to the intercom line. The Green Led next to this button is illuminated while the Talkback circuit is active.

SELECTING MICROPHONE AMPLIFIER GAIN

The microphone preamplifier and the output line drive amplifier have selectable gains allowing the user to tailor the gain structure to the type of microphone being used and the desired output level. Refer to the block diagram on page 28 for a better understanding. As shipped from the factory, the microphone gain is set for a dynamic microphone and the output level is set for -20 dBV*.

The next paragraphs describe how to set the Microphone Amplifier Gain and how to select the line output level.

Microphone Preamplifier Gain

The microphone preamplifier gain must be set to provide proper operation of the limiter circuit used in the Talkback system. The preamplifier can be set for gains of 20, 30, and 40 dB. Dynamic microphones have a nominal output level of approximately -50 dBV. Electret and condenser microphones typically have an output level of -40 dBV. Some microphones have output levels as high as -30 dBV. Jumpers JP9 and JP10 allow selecting the microphone preamplifier gain at 20 dB, 30 dB, and 40 dB. See the table below for setting jumpers.

| INPUT LEVEL | JP-9 | JP-10 |
|----------------------|------|-------|
| -50dB (Dynamic Mic) | 1-2 | 1-2 |
| -40dB (Electret Mic) | 2-3 | 1-2 |
| -30dB | 2-3 | 2-3 |

Line Output Level Select

The operating level at the output is selectable to accommodate the various types of devices that are to be fed. The microphone input of a console would need -50 dBV whereas the line input of a console might need a level of -10 dBV.

Jumper JP8 allows the selection of three gain structures for the output amplifier and the output connector to the rear panel can be plugged into an alternate header on the printed circuit board that has a 30 dB pad inserted in the output. The combination of JP8 and the 30 dB pad allows an output level selection from 0 dBV to -50 dBV in 10 dB steps. See the table below for setting jumpers.

| | 0dB | -10dB | -20dB | -30dB | -40dB | -50dB |
|---------------|------|-------|-------|-------|-------|-------|
| OUTPUT FROM | J2 | J2 | J2 | J3 | J3 | J3 |
| JP8 SELECTION | OPEN | 2-3 | 1-2 | OPEN | 2-3 | 1-2 |

OPTIONS FOR POWER

The AB-100 can be powered from the intercom line, the IFB line, or from a local wall-mount AC transformer. To power it from the intercom line or the IFB line the unit needs a minimum of 25 VDC. The AB-100 draws approximately 65 ma. of current with peaks of 150 ma.

If a condenser microphone is used and it is desired to phantom power the microphone with the internal 48 volt source it will be necessary to locally power the AB-100 with a wall mount transformer.

The following paragraphs describe how to power the AB-100 from the three different sources.

Power From The Intercom Line

To power the unit from the intercom line set a jump jack on pins 1 and 2 of JP5.

Power From The IFB Line

To power the unit from the IFB line, set jump jacks on pins 2 and 3 of JP5 and pins 1 and 2 of JP6 . JP5 selects where the positive DC power is sourced from. JP6 provides a ground return for the DC power.

If for noise reasons, pin 1 of the IFB input connector cannot be connected to power ground of the AB-100 (no jump jack in JP6) the power cannot be derived from the IFB line.

Power From An AC Wall Mount Transformer

If power from the intercom line or IFB line is not available or it is necessary to phantom power a condenser microphone then plug in the 110 VAC wall mount transformer supplied with the unit. An optional 220 VAC transformer is available upon request.

DESCRIPTION OF REAR PANEL CONNECTORS AND CONTROLS

The rear panel of the AB-100 has the following connectors and controls:

- Headset Connector
- Mic Out Connector
- A Male/Female Pair of Intercom Connectors
- IFB Input Connector
- Matrix/AUX Connector
- 24 VAC Power Connector
- Channel Select Switch

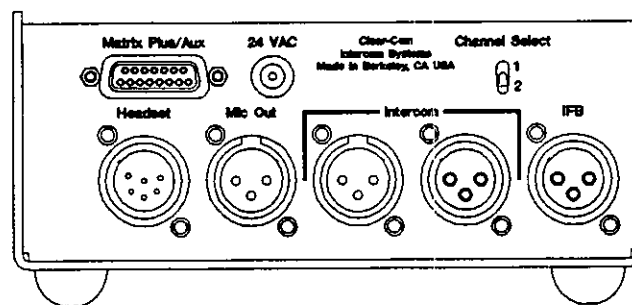

REAR VIEW

The rest of this section describes each in detail.

Headset Connector

STANDARD (As Shipped): The AB-100 is designed for use with any type of sportscaster or announcer headset. Connection is via a 6-pin female XLR style connector on the headset*. The pinout of the headset connector is as follows:

- 1 Microphone Lo (-)
- 2 Microphone Hi (+)
- 3 Headphone Common
- 4 Left Headphone (+)
- 5 Right Headphone (-)
- 6 Microphone Shield

*Switchcraft® Model # A6M or Neutrik® Model # NC6MXS

The headset should have a separate shielded twisted pair of wires directly to the microphone, otherwise some earphone to microphone crosstalk may be experienced.

This connector is also 5-pin compatible, and as such certain standard intercom headsets are wired such that they will plug in directly. If a 5-pin headset connector is used some earphone to microphone crosstalk may be experienced so this option should only be used in emergency situations.

OPTIONS (Customer Supplied Modifications): The construction of the AB-100 lends itself to modification. The 6-pin XLR could be replaced with a 3-pin XLR and used to connect directly to various professional type microphones.

Next to the headset connector is a 1/4 inch hole intended for the user to install a 1/4 inch stereo phone jack for a separate set of headphones. Refer to the schematic on page 29 of this manual for suggested connections in these situations.

The 8-pin header on the printed circuit board that the headset connects to has circuits available for powering of electret and condenser microphones. Refer to the schematic on page 29 for suggested connections in these situations. If a condenser microphone is used and it is desired to phantom power the microphone with the internal 48 volt source, it will be necessary to locally power the AB-100 with a wall-mount transformer.

Mic Out Connector

The Mic Out connector provides a feed of microphone input after amplification. The connector is a XLR-3M. The pinout of this connector is as follows:

- Pin 1 --- Ground (Shield)
- Pin 2 --- + Mic Output
- Pin 3 --- - Mic Output

Intercom Line Connectors (XLR-3 male & female):

The AB-100 has a male and female pair of XLR-3 connectors for the intercom line. The male-female pair of connectors are wired parallel and intended for loop-through connection.

The pinout of the Intercom Connectors when used with Clear-Com Party-Line systems is as follows (place the channel select switch in #2):

- Pin 1 --- Ground (Shield)
- Pin 2 --- Power (+25 to +30 VDC)
- Pin 3 --- Audio

The pinout of the Intercom Connectors when used with TW (RTS) type intercom systems is as follows (place the channel select switch to the desired channel):

- Pin 1 --- Ground (Shield)
- Pin 2 --- Audio #1 & Power (+25 to +30 VDC)
- Pin 3 --- Audio #2

IFB (XLR-3 female):

The AB-100 has female XLR-3 connector for the IFB input. The pinout of the IFB Connector is as follows:

- Pin 1 --- Ground (Shield)
- Pin 2 --- IFB #1 & Power (+25 to +30 VDC)
- Pin 3 --- IFB #2

Matrix Plus/AUX (Rear Panel, DB-15M)

The Matrix Plus/AUX connector is intended for directly connecting a Clear-Com Matrix Plus system. Other 4-wire types of intercoms can also be used via this connector. The following is a description of each group of pins on the connector.

+/- TALK (Pins 2 & 10): The TALK pair is a 600 ohm (0 dB level) transformer balanced output that is active any time the TALKBACK button is active.

+/- LISTEN (Pins 3 & 11): The LISTEN pair is a 10 Kohm (0 dB level) transformer balanced input that is selected with jumper and dip switches. Refer to the application described on page 17.

CALL OUT (Pins 5 & 13): This pair of pins is an opto-isolated output intended to activate the CALL signal input of a Matrix-Plus port input whenever the TALKBACK button is pressed.

CHASSIS (Pin 7): Chassis ground of the AB-100.

24 VAC POWER INPUT (Pins 8 & 15): A second method of entering external power into the AB-100. These pins are parallel to the 2.1 mm coaxial power connector that is normally used with the wall mount transformer.

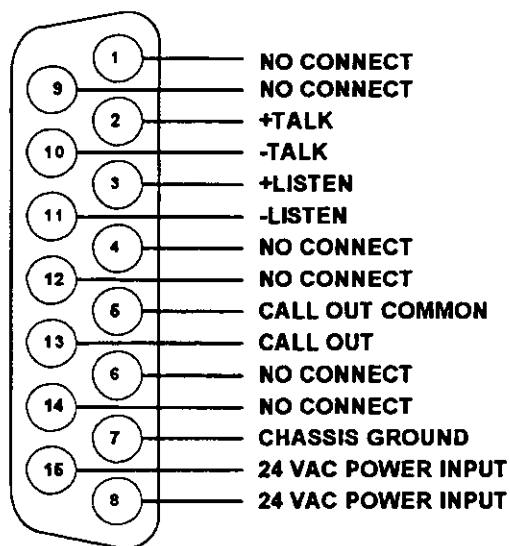

Viewed from the rear of the connector

DESCRIPTION OF INTERNAL JUMPER OPTIONS AND ADJUSTMENTS

The AB-100 has internal jumper options, connector selectable microphone output levels, dip switch selection of earphone output, and headphone sidetone adjustment controls.

As shipped from the factory, the AB-100 has its internal jumpers and Dip switches set to implement the Clear-Com Party-Line setup described on page 15 of this manual. The unit is set up for SPORTSCASTER MODE operation and the Mic Output level is set for -20 dB. The unit will operate on power from the intercom line or from a wall-mounted transformer.

All of these jumpers and Dip switch settings may need to be set depending on the application. The next section of this manual (APPLICATION OF VARIOUS INTERCOM SYSTEM TYPES) discusses four general types of applications and how to setup the AB-100 for each. The text here is for reference only in describing the function of each jumper and dip switch.

To gain access to the internal options, remove the bottom cover by unscrewing the four rubber feet first. If the second channel board is installed it may be necessary to remove the front two screws holding it in place and then swing it up out of the way on its hinged standoffs.

JUMPER OPTIONS

There are eleven two-position jumpers that provide many options for the operation of the AB-100. To access these jumpers, remove the bottom cover of the unit. Inside the bottom cover is a label describing the function of each jumper and dip switch. The following is a description of each jumper

JP1: JP1 provides termination for the intercom line if needed. The AB-100 is always a remote intercom station and therefore does not provide termination for an intercom line. This termination is provided for the cases where the party-line output of the AB-100 is not used and the party-line line drive circuit needs termination to be stable and not oscillate. As shipped from the factory the jumper is between pins 1 and 2 of JP1 making the termination inactive. To activate the termination, place the jumper between pins 2 and 3.

JP2 & JP3: JP2 and JP3 switch the second IFB input (first TW) from the IFB connector to the 4-wire listen input on the DB-15 connector. JP2 and JP3 should always be moved together. With the jump jacks in position 1 and 2, the input is from pins 1 and 2 of the IFB connector. With the jump jacks

between pins 2 and 3, the input is from the DB-15 connector. As shipped from the factory, the jumpers are between pins 1 and 2.

JP4: JP4 selects which pin of the IFB connector the return for the first IFB input (2nd RTS) is on. If JP2 and JP3 are between pins 1 and 2 then JP4 should be between pins 1 and 2. If JP2 and JP3 are between pins 2 and 3 and it is desired to have a balanced input from the IFB connector, place the jumper on JP4 between pins 2 and 3. As shipped from the factory the jumpers are between pins 1 and 2.

JP5: JP5 allows the selection of the source of power for the AB-100. Placing the jumper between pins 1 and 2 of JP5 powers the AB-100 from pin 2 of the intercom connectors. Placing the jumper between pins 2 and 3 of JP5 powers the unit from pin 2 of the IFB connector. Refer to page 7 of this manual for more information.

JP6: JP6 provides options for the ground return pin of the IFB connector. JP6 is shipped from the factory with its jumper between pins 1 and 2 connecting pin 1 of the IFB connector to the internal ground of the AB-100. In some cases having pin 1 of the IFB connector grounded causes ground loops and in those cases the ground should be lifted (place the jump jack only on pin 2 to keep from losing it). In some situations it is possible that noise might be reduced by grounding pin 1 of the IFB connector to the chassis of the AB-100 (place the jump jack between pins 2 and 3).

JP7: JP7 allows the send gain on the talkback channel to be increased when driving a TW-type intercom line, such as RTS. Placing the jumper between pins 2 and 3 increases the send gain approximately 4 dB. JP7 is shipped from the factory with its jumper between pins 1 and 2, providing Clear-Com standard levels to the intercom line.

JP8: JP8 provides selection of desired output level for the microphone output. Refer to page 6 of this manual for detailed information.

JP9 & JP10: JP9 and JP10 select the gain of the microphone amplifier. Refer to page 6 of this manual for detailed information.

JP11: JP11 selects the SPORTSCASTER or ANNOUNCER modes of operation for the front panel pushbutton switches. Refer to page 4 of this manual for detailed information. Connection between pins 1 and 2 enables the SPORTSCASTER mode. Connection between pins 2 and 3 enables the ANNOUNCER mode.

MICROPHONE OUTPUT PAD

The microphone output connector on the rear panel of the AB-100 can be internally plugged into two different headers on the main PCB. Connecting the output to J2 provides a high level output. Connecting the output to J3 adds a 30 dB pad in series to provide a lower level output. Refer to page 6 of this manual for more information.

DIP SWITCH SELECTION OF EARPHONE OUTPUT

Each earphone amplifier has an eight position dip switch providing a selection of inputs to that amplifier. S2 is for the Left Ear and S3 is for the Right Ear. Any or all of the inputs can be selected at the same time. The function of each dip switch is shown below.

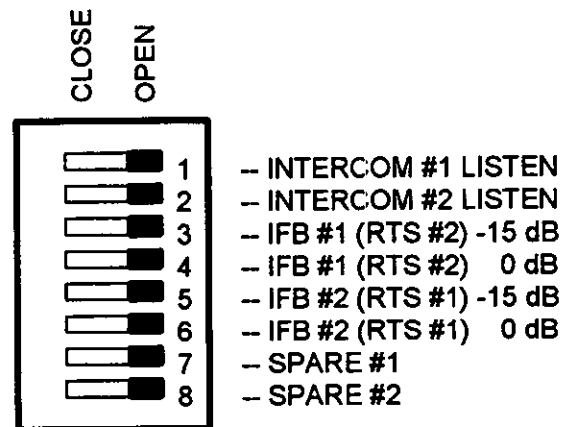

DIP SWITCH SETTINGS FOR S2 AND S3

It will be noted that each of the IFB inputs has two dip switches, and each has different gains associated with it. Dip switch #4 is for a 0 dB input on that IFB channel. Dip switch #3 is for a lower level on the same IFB input. If the IFB source is a balanced input or from a TW-type system then the 0 dB setting should be used. If the IFB source is from a Clear-Com Party-Line system then the -15 dB setting should be used.

HEADPHONE SIDETONE ADJUSTMENT

If either Talkback channel is selected for listening in the headphone, adjust R41 on the main PCB or R6 on the second channel PCB for the desired amount of Talkback that is to be heard in the earphone.

APPLICATION OF VARIOUS INTERCOM SYSTEM TYPES

The AB-100 is intended to work with virtually any intercom system. Options, jumpers and connectors have been provided for the following types of systems. This section describes how to implement each system type:

- Clear-Com Party-Line
- Matrix Plus Digital Intercom Systems
- TW Party-Line Systems (RTS)
- Other 4-wire Systems

Clear-Com Party-Line

An all Clear-Com Party-Line system would be described as follows:

IFB: IFB is provided by a PIC-4000B 2 channel (interrupt and non-interrupt) IFB system.

INTERCOM: Talkback is provided from one channel of a Clear-Com Party-Line system. This single channel is the "Producer Channel." Any announcer pressing his or her "Talkback" button would talk on this channel. Any or all of the announcers may talk at any time as they are summed on the party-line channel.

Set the Channel Select switch on the rear panel of the AB-100 to '2'.

POWER: Power for the AB-100 is derived from the intercom line, or optionally from the IFB line. Refer to page 7 for instructions about powering from the intercom or IFB lines.

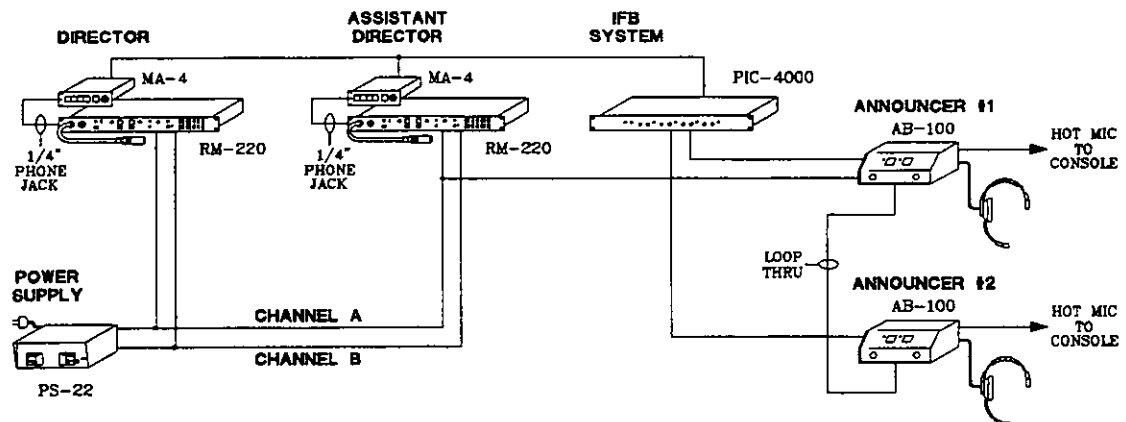

AB-100 Connected To A Clear-Com Party-line System

SETTING JUMPERS:

| | | |
|-------|---------------------|---|
| JP-1 | -- 1-2 | (UNTERMINATE INTERCOM LINE) |
| JP-2 | -- 1-2 | (UNBALANCED #2 INPUT FROM IFB CONNECTOR) |
| JP-3 | -- 1-2 | (UNBALANCED #2 INPUT FROM IFB CONNECTOR) |
| JP-4 | -- 1-2 | (UNBALANCED #1 INPUT FROM IFB CONNECTOR) |
| JP-5 | -- 1-2 | (POWER INTERCOM LINE) |
| JP-6 | -- 1-2 | (CONNECT SHIELD OF IFB TO GROUND OF AB-100) |
| JP-7 | -- 1-2 | (CLEAR-COM INTERCOM LEVEL) |
| JP-8 | -- MIC OUTPUT LEVEL | (SET PER CHART ON PAGE 6) |
| JP-9 | -- MIC PREAMP GAIN | (SET PER CHART ON PAGE 6) |
| JP-10 | -- MIC PREAMP GAIN | (SET PER CHART ON PAGE 6) |
| JP-11 | -- MODE SELECT | (SEE DISCUSSION PAGE 4) |

CHANNEL SELECT SWITCH: -- '2' unless second talkback channel installed.
'1' with second talkback channel installed.

SETTING DIP SWITCHES:

| S2 (Left Ear Select) | S3 (Right Ear Select) |
|----------------------|-----------------------|
| #1 -- OPEN(1) | #1 -- OPEN |
| #2 -- OPEN | #2 -- OPEN(2) |
| #3 -- CLOSE | #3 -- OPEN |
| #4 -- OPEN | #4 -- OPEN |
| #5 -- OPEN | #5 -- CLOSE |
| #6 -- OPEN | #6 -- OPEN |
| #7 -- OPEN | #7 -- OPEN |
| #8 -- OPEN | #8 -- OPEN |

- (1) If listen on the talkback channel is desired.
- (2) If the second talkback channel is available and listen to it is desired.

WIRING OF CONNECTORS:

The pinout for the intercom XLR-3 connector is as follows:

- Pin 1 -- Ground
- Pin 2 -- +30 Volts Power
- Pin 3 -- Intercom Audio

The pinout for the IFB XLR-3F connector is as follows:

- Pin 1 -- Ground
- Pin 2 -- IFB #2 (and power)
- Pin 3 -- IFB #1

Matrix Plus Digital Intercom Systems

The Matrix Plus Digital Intercom system connects directly via the DB-15M on the rear panel of the AB-100. A description of such a system is as follows:

IFB: IFB is provided by a separate port of the Matrix Plus or an uninterrupted source such as an On-The-Air feed. This port output could be a standard port output directly from the matrix frame without an interface or it could be an output directly from an IP-50 interface panel connected to the expansion ports of a System III frame. Jumpers are set in the AB-100 to make the IFB input transformer balanced.

INTERCOM: Talkback is provided from a dedicated port on the Matrix Plus. The port is declared as a general purpose 4-wire port by connecting an ID jumper on pins 7 and 15 of the DB-15 Matrix port connector. The listen portion of the intercom port is sent to the left ear while the IFB input is sent to the right ear.

Alternately, a single port can be used for Program feed to the talent using the AB-100 and for Matrix communication to the talent with the talkback from the talent going into the Matrix port.

The Talkback button has an isolated logic output that can be connected to the CALL receive input of the Matrix Plus port. That port of the matrix should be set for a preset CALL Signal and Activate Crosspoints on CALL. Pressing the Talkback button on the AB-100 will cause the matrix to send a CALL signal to any ports that have been designated and close crosspoints for as long as the Talkback button is pressed.

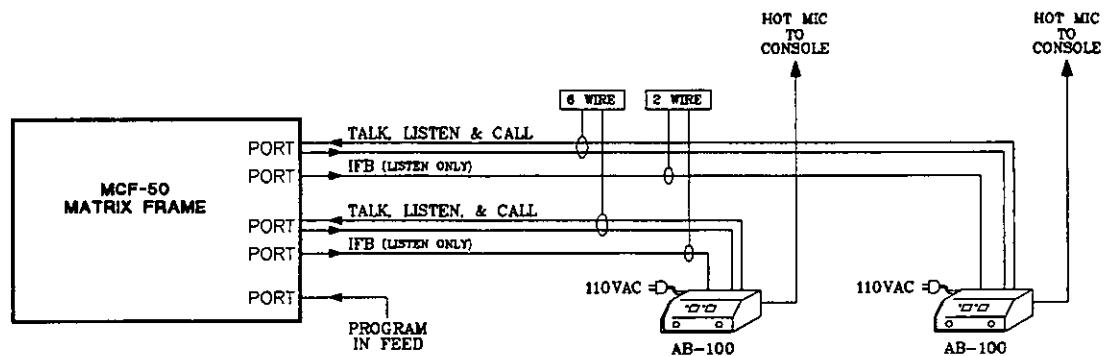

AB-100 Connected To A Matrix Plus System

POWER: Power for the AB-100 is provided by an AC wall-mount transformer or a powered PL cable whether or not the Party-Line is used in the AB-100.

SETTING JUMPERS:

- JP-1 -- 2-3 (TERMINATE UNUSED INTERCOM LINE)
- JP-2 -- 2-3 (BALANCED INPUT FROM MATRIX CONNECTOR)
- JP-3 -- 2-3 (BALANCED INPUT FROM MATRIX CONNECTOR)
- JP-4 -- 2-3 (BALANCED INPUT FROM IFB CONNECTOR)
- JP-5 -- 1-2 (POWER FROM PL INTERCOM LINE IF AVAILABLE)
- JP-6 -- 2-3 (CONNECT SHIELD OF IFB TO CHASSIS OF AB-100)
- JP-7 -- DOES NOT APPLY (CLEAR-COM/RTS INTERCOM LEVEL)
- JP-8 -- MIC OUTPUT LEVEL (SET PER CHART ON PAGE 6)
- JP-9 -- MIC PREAMP GAIN (SET PER CHART ON PAGE 6)
- JP-10 -- MIC PREAMP GAIN (SET PER CHART ON PAGE 6)
- JP-11 -- MUTE BUTTON SELECT (SEE DISCUSSION PAGE 4)

CHANNEL SELECT SWITCH: -- '2'

If the second talkback channel is installed it will not be operational.

SETTING DIP SWITCHES:

Set the Dip switches for selection of what will be heard in each ear. S2 for the left ear and S3 for the right ear. Close = ON

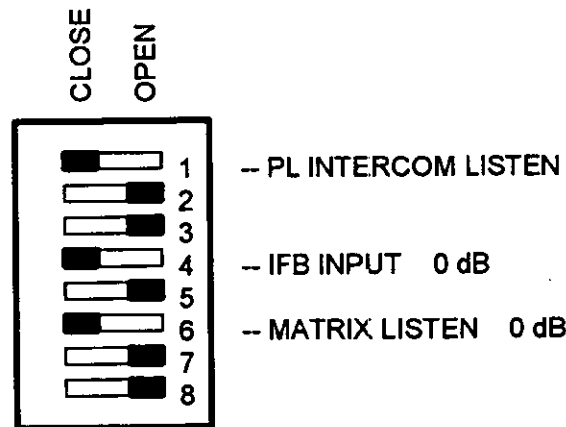

DIP SWITCH SETTINGS FOR S2 AND S3

WIRING OF CONNECTORS: Make up the following cables to connect between the AB-100 and the Matrix Plus.

**REAR OF DB-15F CABLE
CONNECTOR ON AB-100**

**REAR OF DB-15M CABLE
CONNECTOR ON MATRIX**

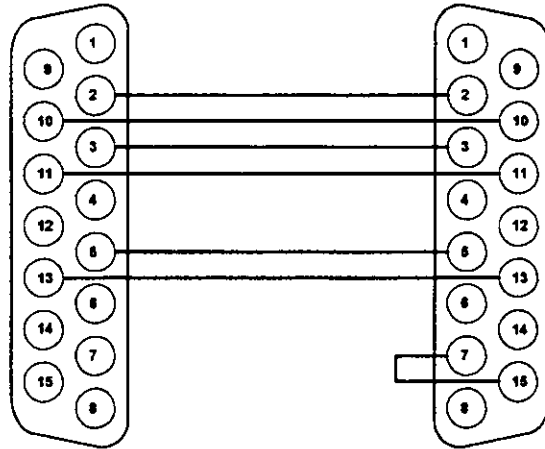

INTERCONNECT CABLE BETWEEN THE AB-100 AND A MATRIX PLUS PORT

**XLR-3M CABLE
CONNECTOR ON AB-100**

**REAR OF 15-15M CABLE
CONNECTOR ON MATRIX**

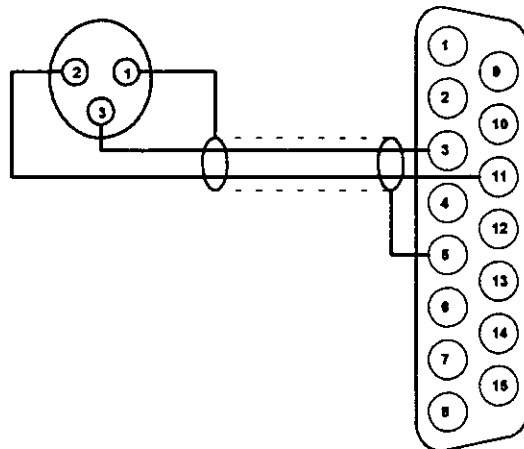

IFB INTERCONNECTCABLE BETWEEN THE AB-100 AND A MATRIX PLUS PORT

TW Party-Line Systems (RTS)

A TW party-line system would be described as follows:

IFB: IFB is provided by a 2 channel (interrupt and non-interrupt) IFB system.

INTERCOM: Talkback is provided from one or two channels of a TW party-line system. Channel '1' is the "Producer Channel", any announcer pressing his or her "talkback" button would talk on this channel. Any or all of the announcers may talk at any time as they are summed on the party-line channel.

Set the Channel Select switch on the rear panel of the AB-100 to '1'.

If the second channel option is installed, any announcer pressing his or her "mute" button would talk on that channel.

POWER: Power for the AB-100 is derived from the intercom line, or optionally from the IFB line. Refer to page 7 of this manual for instructions about powering from the intercom or IFB lines.

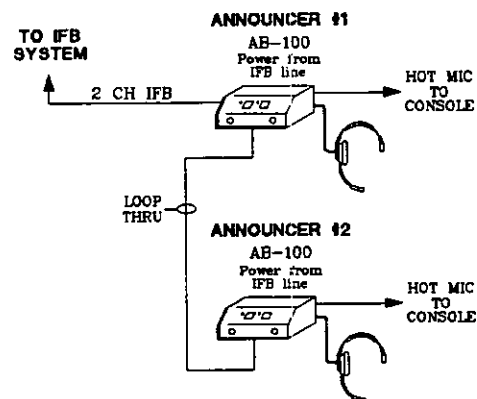

AB-100 Connected To A TW Party-line System

SETTING JUMPERS:

- JP-1 -- 1-2 (UNTERMINATE INTERCOM LINE)
 JP-2 -- 1-2 (UNBALANCED #1 INPUT FROM IFB CONNECTOR)
 JP-3 -- 1-2 (UNBALANCED #1 INPUT FROM IFB CONNECTOR)
 JP-4 -- 1-2 (UNBALANCED #2 INPUT FROM IFB CONNECTOR)
 JP-5 -- 1-2 (POWER INTERCOM LINE)
 JP-6 -- OPEN (LET COMMON OF IFB FLOAT)
 JP-7 -- 2-3 (RTS INTERCOM LEVEL) & JP-1 ON THE OPTION BOARD IF USED.
 JP-8 -- MIC OUTPUT LEVEL (SET PER CHART ON PAGE 6)
 JP-9 -- MIC PREAMP GAIN (SET PER CHART ON PAGE 6)
 JP-10 -- MIC PREAMP GAIN (SET PER CHART ON PAGE 6)
 JP-11 -- MUTE BUTTON SELECT (SEE DISCUSSION PAGE 4)

CHANNEL SELECT SWITCH: -- '1'

SETTING DIP SWITCHES:

| S2 (Left Ear Select) | S3 (Right Ear Select) |
|----------------------|-----------------------|
| #1 -- OPEN(1) | #1 -- OPEN |
| #2 -- OPEN | #2 -- OPEN(2) |
| #3 -- CLOSE | #3 -- OPEN |
| #4 -- OPEN | #4 -- OPEN |
| #5 -- OPEN | #5 -- CLOSE |
| #6 -- OPEN | #6 -- OPEN |
| #7 -- OPEN | #7 -- OPEN |
| #8 -- OPEN | #8 -- OPEN |

- (1) If listen on the talkback channel is desired.
 (2) If the second talkback channel is available and listen to it is desired.

WIRING OF CONNECTORS:

The pinout for the intercom XLR-3 connector is as follows:

- Pin 1 -- Ground
 Pin 2 -- Intercom Audio #1 and +30 Volts Power
 Pin 3 -- Intercom Audio #2

The pinout for the IFB XLR-3F connector is as follows:

- Pin 1 -- Ground
 Pin 2 -- Audio #1
 Pin 3 -- Audio #2

Other 4-wire Systems

A generic 4-wire intercom system can connect directly via the DB-15M on the rear panel of the AB-100. A description of such a system is as follows:

IFB: A single channel of IFB is provided by a separate 2-wire input. Jumpers are set in the AB-100 to make the IFB input transformer balanced.

INTERCOM: Talkback is provided from a 4-wire port of a point-to-point matrix system. The listen portion of the intercom port is sent to the left ear while the IFB input is sent to the right ear.

POWER: Power for the AB-100 is provided by an AC wall-mount transformer.

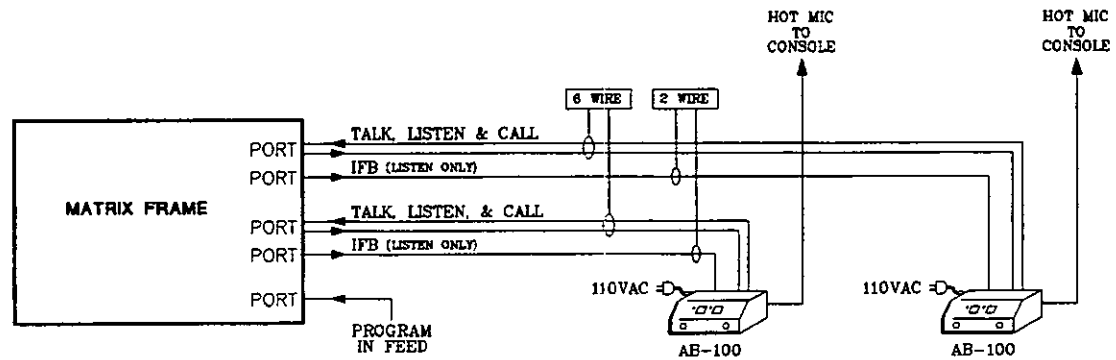

AB-100 Connected To A 4-Wire Matrix System

SETTING JUMPERS:

- JP-1 -- 2-3 (TERMINATE UNUSED INTERCOM LINE)
- JP-2 -- 2-3 (BALANCED INPUT FROM MATRIX CONNECTOR)
- JP-3 -- 2-3 (BALANCED INPUT FROM MATRIX CONNECTOR)
- JP-4 -- 2-3 (BALANCED INPUT FROM IFB CONNECTOR)
- JP-5 -- OPEN (POWER NOT FROM IFB OR INTERCOM LINE)
- JP-6 -- 2-3 (CONNECT SHIELD OF IFB TO CHASSIS OF AB-100)
- JP-7 -- DOES NOT APPLY (CLEAR-COM/RTS INTERCOM LEVEL)
- JP-8 -- MIC OUTPUT LEVEL (SET PER CHART ON PAGE 6)
- JP-9 -- MIC PREAMP GAIN (SET PER CHART ON PAGE 6)
- JP-10 -- MIC PREAMP GAIN (SET PER CHART ON PAGE 6)
- JP-11 -- MUTE BUTTON SELECT (SEE DISCUSSION PAGE 4)

CHANNEL SELECT SWITCH: -- '2'

If the second talkback channel is installed it will not be operational.

SETTING DIP SWITCHES:

| S2 (Left Ear Select) | S3 (Right Ear Select) |
|----------------------|-----------------------|
| #1 -- OPEN | #1 -- OPEN |
| #2 -- OPEN | #2 -- OPEN |
| #3 -- OPEN | #3 -- OPEN |
| #4 -- CLOSE | #4 -- OPEN |
| #5 -- OPEN | #5 -- OPEN |
| #6 -- OPEN | #6 -- CLOSE |
| #7 -- OPEN | #7 -- OPEN |
| #8 -- OPEN | #8 -- OPEN |

WIRING OF CONNECTORS:

The pinout for the DB-15M connector is as follows:

- Pin 2 -- +Talk
- Pin 10 -- -Talk
- Pin 3 -- +Listen
- Pin 11 -- -Listen

The pinout for the IFB XLR-3F connector is as follows:

- Pin 1 -- Ground
- Pin 2 -- +IFB
- Pin 3 -- -IFB

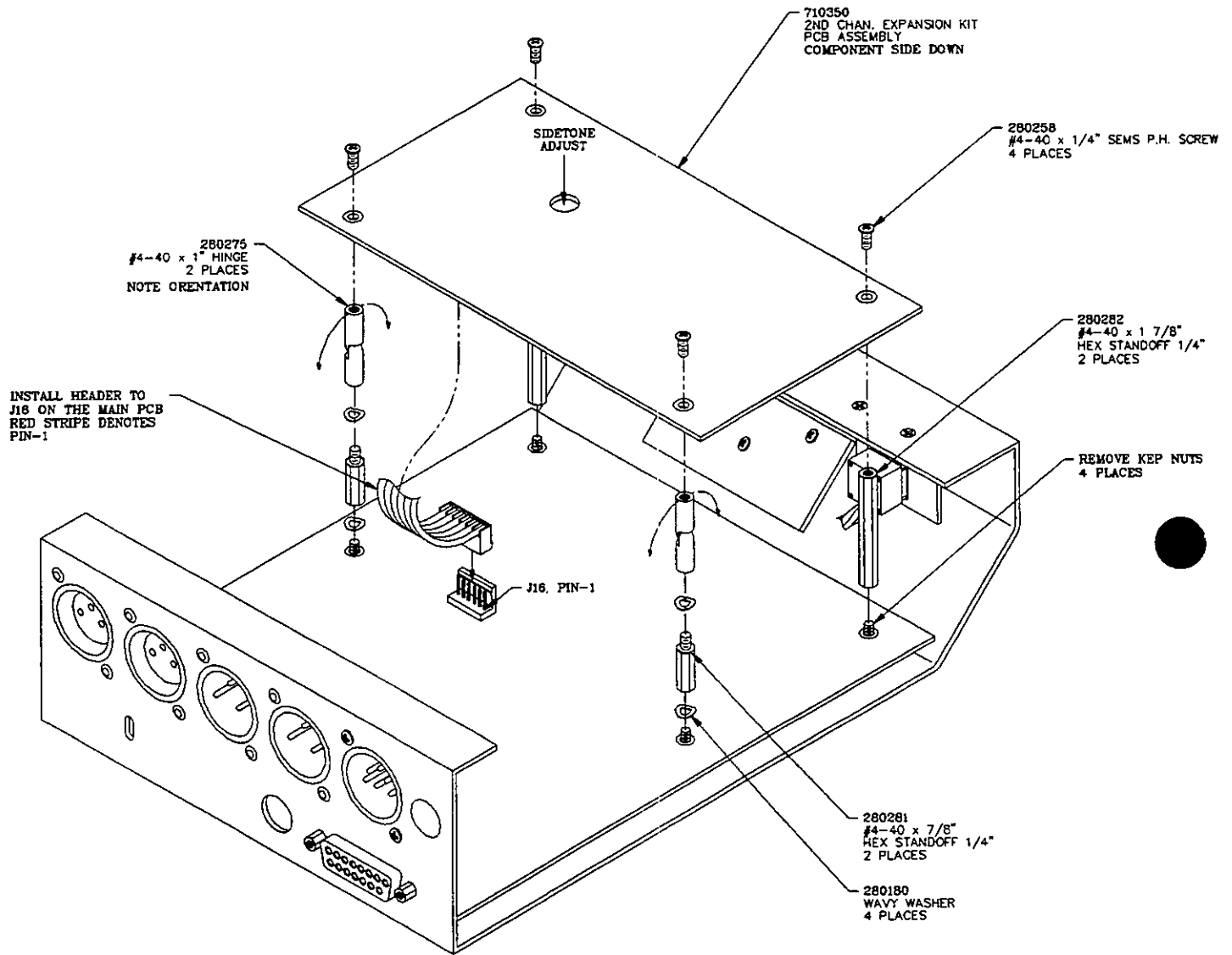

INSTALLATION OF SECOND CHANNEL OPTION PCB

INSTALLATION OF SECOND CHANNEL OPTION BOARD

A kit that allows the implementation of a second intercom channel is available for the AB-100. It is Clear-Com part # 820073. If it is ordered at the time of purchase of the AB-100, it will be factory installed and tested. If it is ordered separately, the user will need to install the option.

The following instructions are for field installation of the second channel option kit. Refer to the illustration on the next page for details.

- 1 Remove the bottom cover by unscrewing the four rubber feet first.
- 2 Remove four #4 kep nuts holding the front portion of the main PCB down.
- 3 Replace the front two nuts with the two 1 7/8 inch standoffs supplied with the kit. Use two internal tooth lock washers next to the PCB. Tighten the standoffs very well.
- 4 Replace the rear two nuts with the two 7/8 inch standoffs supplied with the kit. Use two internal tooth lock washers next to the PCB. Tighten the standoffs very well.
- 5 Place the wavy washers on the two standoffs installed in the previous step. Screw the two hinged standoffs onto those standoffs. The hinged standoffs need to be very tight but care must be taken to turn the direction of swing of the hinge such that it swings from the front to the back of the unit.
- 6 Connect the ribbon cable of the second channel board into J16 of the main PCB.
- 7 Using the four 4-40 screws, mount the option PCB to the four standoffs.
- 8 Replace the bottom cover of the unit.

OPERATION

Once installed and configured, the operation of the AB-100 is very simple. The action of the two front panel pushbuttons depends on the mode selected: SPORTSCASTER MODE or ANNOUNCERS MODE.

The volume controls operate the same in both modes. The control marked LEFT sets the listen volume in the left ear and the control marked RIGHT sets the listen volume in the right ear.

The operation of the pushbuttons and Leds are described for the two modes of operation:

SPORTSCASTER MODE

MUTE BUTTON (Left Button): Pressing the MUTE button turns the microphone output off while the button is pressed.

If the second intercom channel option is installed, the microphone output will be sent to the second talkback channel while the MUTE button is pressed.

MIC ON LED (Red): The red Led is on whenever the microphone input is being feed to its output.

TALKBACK BUTTON (Right Button): Pressing the TALKBACK button sends the microphone to channel 1 of the intercom circuits and turns off the microphone output.

TALKBACK LED (Green): When the green Led is on it indicates that the microphone is being sent to the first talkback channel.

ANNOUNCERS MODE

MIC ON/OFF BUTTON (Left Button): Pressing the MIC ON/OFF button toggles the microphone output on if it was off and off if it was on.

NOTE: In the ANNOUNCER MODE use of the second talkback channel is not recommended. There is no indication when the second channel talkback is active. If the second talkback channel is used it is active only while the MIC ON/OFF button is pressed. Its active state does not follow the RED LED.

MIC ON LED (Red): The red led is on whenever the microphone input is being feed to its output.

TALKBACK BUTTON (Right Button): Pressing the TALKBACK button sends the microphone to channel 1 of the intercom circuits and turns off the microphone output. The MIC ON/OFF latch is also cleared such that it will be off when the TALKBACK button is released.

TALKBACK LED (Green): When the green led is on it indicates that the microphone is being sent to the first talkback channel.

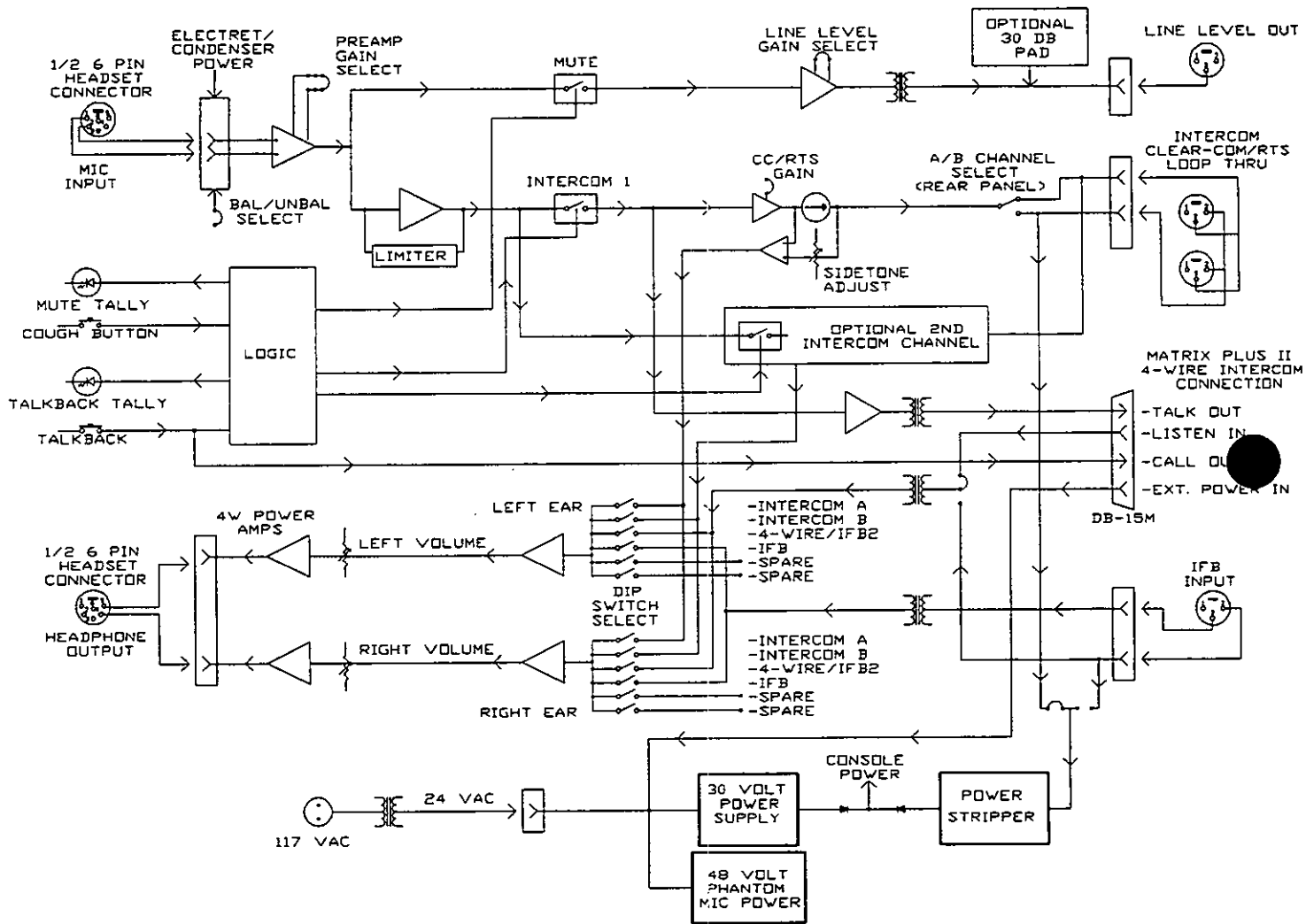

Block Diagram for the AB-100

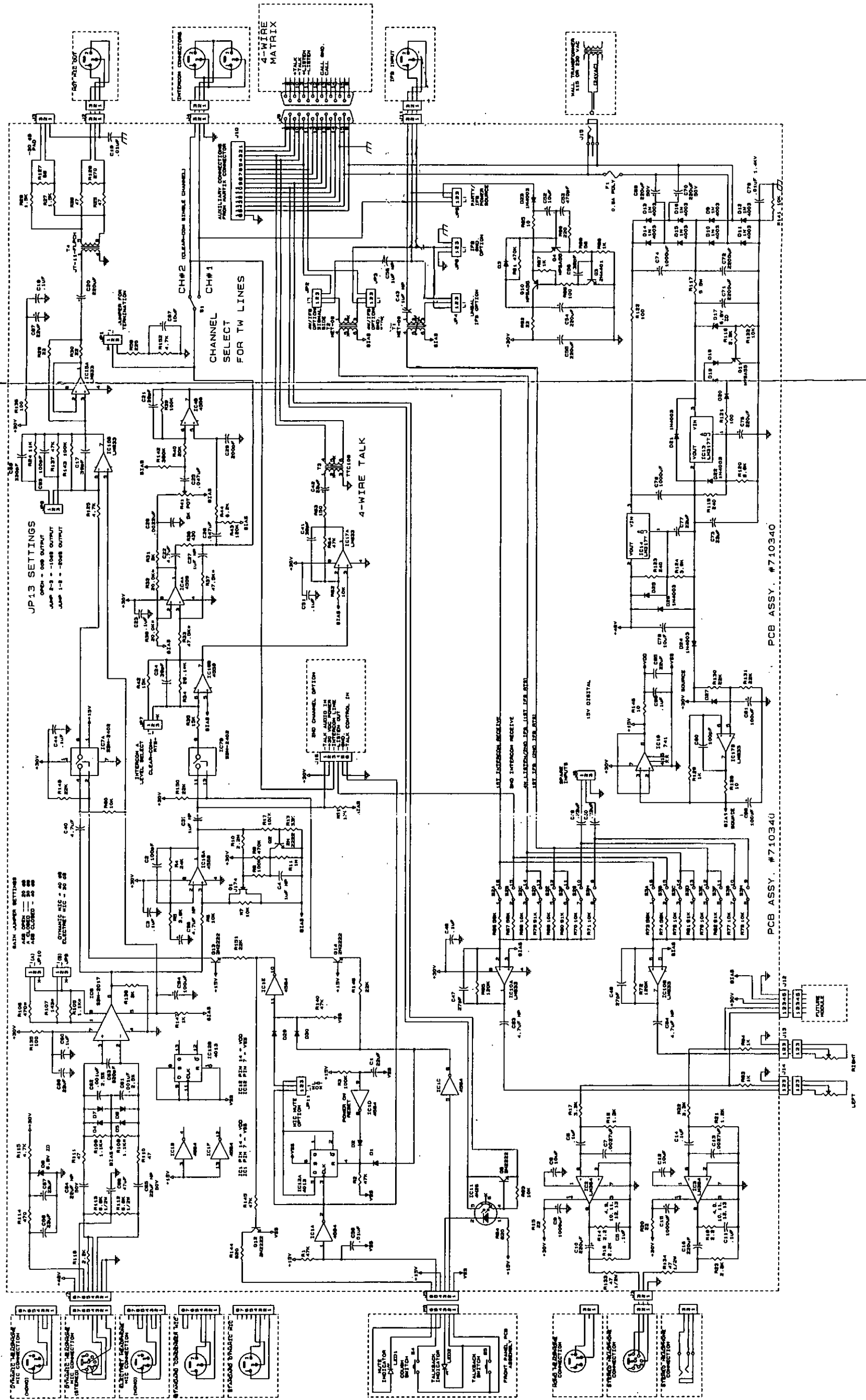

Schematic Diagram for the AB-100

INSTALL S4 AND S5 KEYCAP
SECOND LOAD, SEE DETAIL 'B'

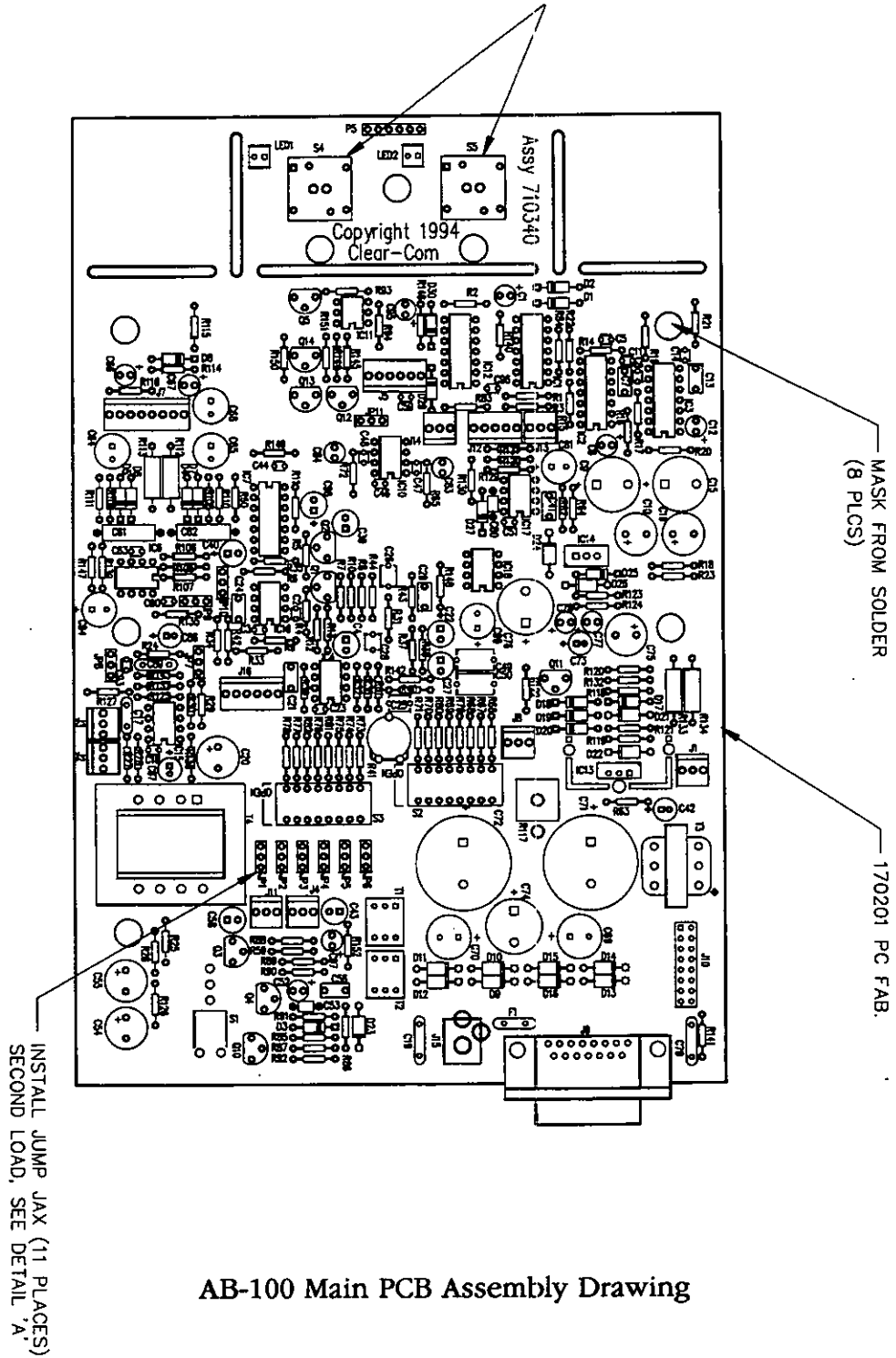

AB-100 Main PCB Assembly Drawing

BILL OF MATERIALS OF MISC. CHASSIS PARTS

| Device | Description | Part # | Designator |
|-------------|--------------------------|--------|------------|
| FOOT | RUBBER FOOT 3/4IN ROUND | 240087 | |
| POT | 10K POT PANEL MOUNT | 470073 | |
| TRANSFORMER | 110V/24V 0.4A WALL MOUNT | 400007 | |

BILL OF MATERIALS FOR THE PCB ASY**Capacitors**

| Value | Type | Volts | Tol. | Part # | Designator | |
|-------|------|-------------|-------|--------|------------|--|
| 27 | PF | CERAMIC | 50V | 5% | 150071 | C47,C48 |
| 39 | PF | CERAMIC | 50V | 5% | 150026 | C17,C21,C24,C41,C56 |
| 100 | PF | CERAMIC | 50V | 10% | 150006 | C2,C80 |
| 200 | PF | CERAMIC | 100V | 5% | 150063 | C29 |
| 330 | PF | CERAMIC | 50V | 5% | 150025 | C89 |
| 470 | PF | CERAMIC | 50V | 10% | 150014 | C53 |
| 820 | PF | MONOLITHIC | 50V | 5% | 150101 | C63 |
| 1000 | PF | PLY | 50V | 2.5% | 150119 | C61,C62 |
| .0022 | UF | MYLAR | 100V | 5% | 150045 | C28 |
| .0027 | UF | MYLAR | 50V | 5% | 150148 | C7,C13 |
| .01 | UF | CERAMIC | 1.4KV | 20% | 150029 | C19,C59,C79 |
| .047 | UF | MYLAR | 100V | 5% | 150131 | C25,C26 |
| .1 | UF | MONOLITHIC | 50V | 10% | 150035 | C3,C5,C8,C11,C14,C18, C23,C44,C46,C51,C60,C96 |
| .22 | UF | MYLAR | 100V | 20% | 150003 | C49,C50 |
| 1 | UF | ALUMINUM NP | 50V | 10% | 150002 | C4,C27,C39,C43,C58 |
| 4.7 | UF | ALUMINUM NP | 50V | | 150087 | C22,C40,C83,C84 |
| 10 | UF | ALUMINUM | 50V | | 150064 | C6,C12,C52,C78,C97 |
| 22 | UF | ALUMINUM NP | 50V | | 150150 | C64,C65 |
| 22 | UF | ALUMINUM | 35V | 20% | 150152 | C42,C73,C86,C87,C95 |
| 22 | UF | ALUMINUM | 16V | | 150010 | C1,C66,C67,C77,C88 |
| 47 | UF | | | | 150154 | C68 |
| 100 | UF | ALUMINUM | 35V | | 150136 | C81,C99 |
| 220 | UF | ALUMINUM | 35V | | 150021 | C10,C16,C20,C54,C55,C75 |
| 220 | UF | ALUMINUM | 50V | | 150037 | C69,C70 |
| 1000 | UF | ALUMINUM | 35V | | 150092 | C9,C15,C74,C76 |
| 2200 | UF | ALUMINUM | 50V | | 150135 | C71,C72 C18,C23,C44,C46 |

Resistors

| Value | Power | Type | Tol. | Part # | Designator |
|------------|-------|-------------|------|--------|--|
| 143 OHMS | 1/4W | METAL FILM | 1% | 410187 | R107 |
| 470 OHMS | 1/4W | METAL FILM | 1% | 410190 | R106 |
| 1.1K OHMS | 1/4W | METAL FILM | 1% | 410189 | R105,R108,R109 |
| 11.0K OHMS | 1/4W | METAL FILM | 1% | 410191 | R24 |
| 20.0K OHMS | 1/4W | METAL FILM | 1% | 410086 | R32,R36,R40 |
| 26.1K OHMS | 1/4W | METAL FILM | 1% | 410192 | R34 |
| 47.5K OHMS | 1/8W | METAL FILM | 1% | 410105 | R33,R37 |
| 2.2 OHMS | 1/4W | CARBON FILM | 5% | 410113 | R14,R19 |
| 10 OHMS | 1/4W | CARBON FILM | 5% | 410002 | R85,R128,R148 |
| 22 OHMS | 1/4W | CARBON FILM | 5% | 410004 | R15,R20,R29,R30,R92 |
| 47 OHMS | 1/4W | CARBON FILM | 5% | 410039 | R25,R26,R110,R111 |
| 56 OHMS | 1/4W | CARBON FILM | 5% | 410135 | R89 |
| 100 OHMS | 1/4W | CARBON FILM | 5% | 410071 | R86,R121,R122,R135,R136 |
| 150 OHMS | 1/4W | CARBON FILM | 5% | 410006 | R63 |
| 220 OHMS | 1/4W | CARBON FILM | 5% | 410007 | R59,R90 |
| 240 OHMS | 1/4W | CARBON FILM | 5% | 410060 | R119,R123 |
| 270 OHMS | 1/4W | CARBON FILM | 5% | 410009 | R126 |
| 430 OHMS | 1/4W | CARBON FILM | 5% | 410106 | R38 |
| 470 OHMS | 1/4W | CARBON FILM | 5% | 410042 | R114 |
| 820 OHMS | 1/4W | CARBON FILM | 5% | 410096 | R94,R144 |
| 1K OHMS | 1/4W | CARBON FILM | 5% | 410010 | R83,R84,R87,R88,R129, R147 |
| 1.2K OHMS | 1/4W | CARBON FILM | 5% | 410041 | R16,R21 |
| 1.5K OHMS | 1/4W | CARBON FILM | 5% | 410055 | R27,R28 |
| 2K OHMS | 1/4W | CARBON FILM | 5% | 410014 | R31,R139 |
| 2.2K OHMS | 1/4W | CARBON FILM | 5% | 410011 | R18,R23,R116,R118 |
| 3.3K OHMS | 1/4W | CARBON FILM | 5% | 410015 | R17,R22 |
| 3.9K OHMS | 1/4W | CARBON FILM | 5% | 410012 | R124 |
| 4.7K OHMS | 1/4W | CARBON FILM | 5% | 410013 | R115,R125,R152 |
| 5.6K OHMS | 1/4W | CARBON FILM | 5% | 410056 | R120 |
| 6.2K OHMS | 1/4W | CARBON FILM | 5% | 410137 | R44 |
| 10K OHMS | 1/4W | CARBON FILM | 5% | 410016 | R6,R7,R60,R61,R62,R68, R69,R70,71,R75,R76,R77, R78,R93,R132,R141 |
| 15K OHMS | 1/4W | CARBON FILM | 5% | 410017 | R35,R42 |
| 22K OHMS | 1/4W | CARBON FILM | 5% | 410018 | R130,R131,R145,R146, R149,R150,R151 |
| 24K OHMS | 1/4W | CARBON FILM | 5% | 410083 | R4 |
| 33K OHMS | 1/4W | CARBON FILM | 5% | 410020 | R13 |

Resistors continued

| Value | Power | Type | Tol. | Part # | Designator |
|-----------|-------|-------------|------|--------|---------------------|
| 47K OHMS | 1/4W | CARBON FILM | 5% | 410021 | R1,R2,R64,R137,R140 |
| 56K OHMS | 1/4W | CARBON FILM | 5% | 410023 | R66,R67,R73,R74 |
| 91K OHMS | 1/4W | CARBON FILM | 5% | 410049 | R79,R80,R81,R82 |
| 100K OHMS | 1/4W | CARBON FILM | 5% | 410024 | R3,R8,R12,R39 |
| 120K OHMS | 1/4W | CARBON FILM | 5% | 410079 | R43,R65,R72 |
| 470K OHMS | 1/4W | CARBON FILM | 5% | 410030 | R9,R91,R143 |
| 1M OHMS | 1/4W | CARBON FILM | 5% | 410058 | R11 |
| 2.2M OHMS | 1/4W | CARBON FILM | 5% | 410153 | R10 |
| 47 OHMS | 1/2W | CARBON FILM | 5% | 410134 | R133,R134 |
| 6.8K OHMS | 1/2W | CARBON FILM | 5% | 410188 | R112,R113 |
| 5 OHMS | 5W | WIRE WOUND | 10% | 410051 | R117 |

Integrated Circuits and Semiconductors

| Device | Description | Part # | Designator |
|------------|-----------------------------|--------|--|
| DIODE | 1N957B ZENER 6.8V .4W 5% | 480026 | D8,D17 |
| DIODE | 1N4003 RECT 1A 200PIV | 480058 | D9,D10,D11,D12 D13,D14,D21,D22 D23,D24,D26 |
| DIODE | 1N4148 SIGNAL 10MA 75PIV | 480000 | D1,D2,D3,D4,D5 D6,D7,D18,D19,D20 D25,D27,D29,D30 |
| I.C. | SSM-2017 BAL INPUT PREAMP | 480207 | IC6 |
| I.C. | SSM-2402 DUAL SWITCH | 480208 | IC7 |
| I.C. | 4013 CMOS DUAL D FLIP FLOP | 480171 | IC12 |
| I.C. | 4584B CMOS HEX SCMITT TRIG | 480090 | IC1 |
| I.C. | 4N26 OPTO COMPILER | 480106 | IC11 |
| LED | RED, ROUND T1-3/4 20-30 MA | 480064 | LED1 |
| LED | GREEN, ROUND T1-3/4 20-30MA | 390051 | LED2 |
| OP-AMP | RC4559NB DUAL OP AMP | 480056 | IC4,IC16 |
| OP-AMP | LM741 IC OP AMP 8 PIN DIP | 480018 | IC18 |
| OP-AMP | LM384 POWER OP AMP | 480012 | IC2,IC3 |
| OP-AMP | LM833N DUAL 8 PIN DIP | 480175 | IC10,IC15,IC17 |
| REGULATOR | LM317T POS ADJ 1.5A | 480167 | IC13,IC14 |
| TRANSISTOR | MPS-A55 PNP 60V | 480050 | Q4,Q10,Q11 |
| TRANSISTOR | 2N4401 NPN 40V | 480047 | Q3 |
| TRANSISTOR | J174 JFET PCHAN 8V VGS | 480079 | Q1 |
| TRANSISTOR | 2N2222 NPN 30V | 480006 | Q2,Q5,Q12,Q13,Q14 |

Mics. PCB Parts

| Device | Description | Part # | Designator |
|---------------|----------------------------|---------------|-------------------|
| CONNECTOR | 2.1MM CO-AX PC MTG POWER | 210213 | J15 |
| CONNECTOR | DB15-M RT ANG PC MTG | 210188 | J9 |
| FUSE | 0.90A POLY SWITCH | 520036 | F1 |
| JUMP JACK | JUMP JACK WITH HANDLE | 210226 | JP1-JP11 |
| POT | 5K TRIM POT H MTG. | 470022 | R41 |
| SWITCH | PUSHBUTTON SWITCH | 510108 | S4,S5 |
| SWITCH | SPDT RT ANG PC MTG | 510098 | S1 |
| SWITCH | 8 POS DIP SWITCH | 510078 | S2,S3 |
| TRANSFORMER | 600CT/600CT PAN MAG#TTC108 | 560018 | T3 |
| TRANSFORMER | 10K:10K MINIATURE AUDIO | 560034 | T1,T2 |
| TRANSFORMER | 600:600 HI OUT LOW DISTORT | 560038 | T4 |

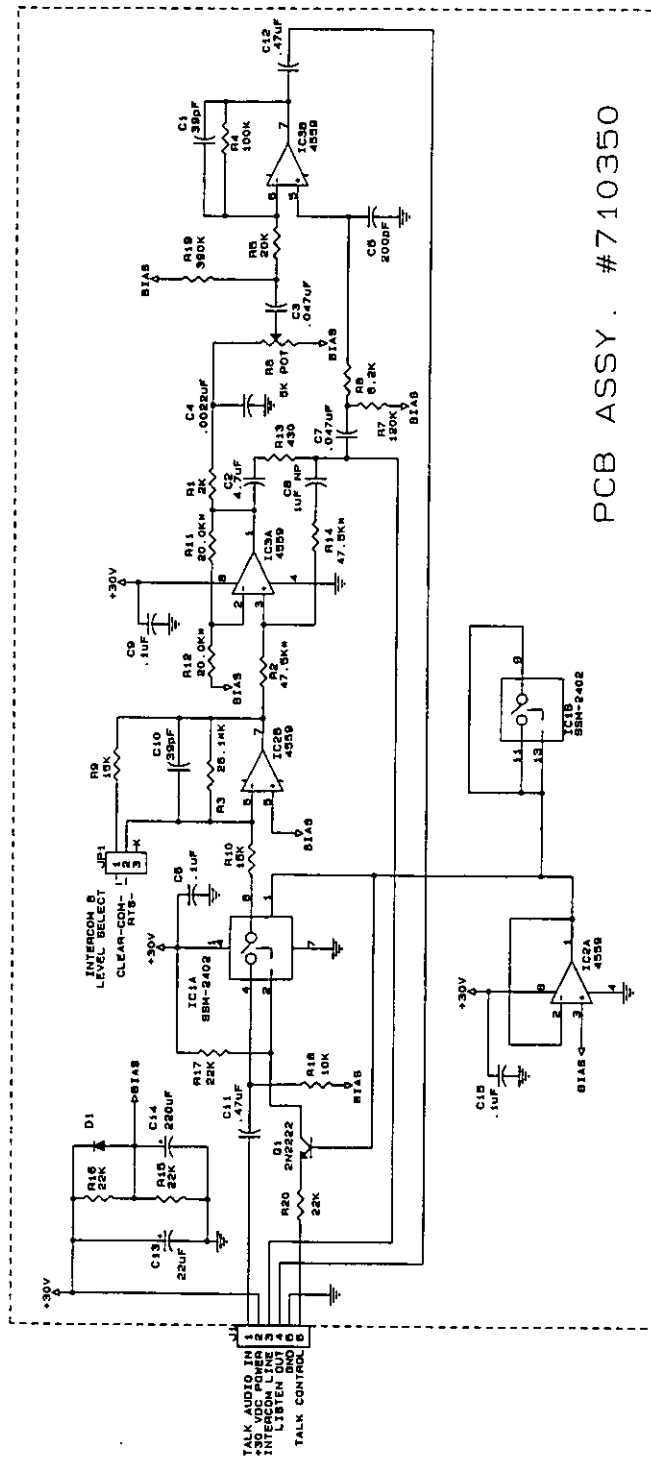

Schematic Diagram for the AB-100 Second Channel Option PCB

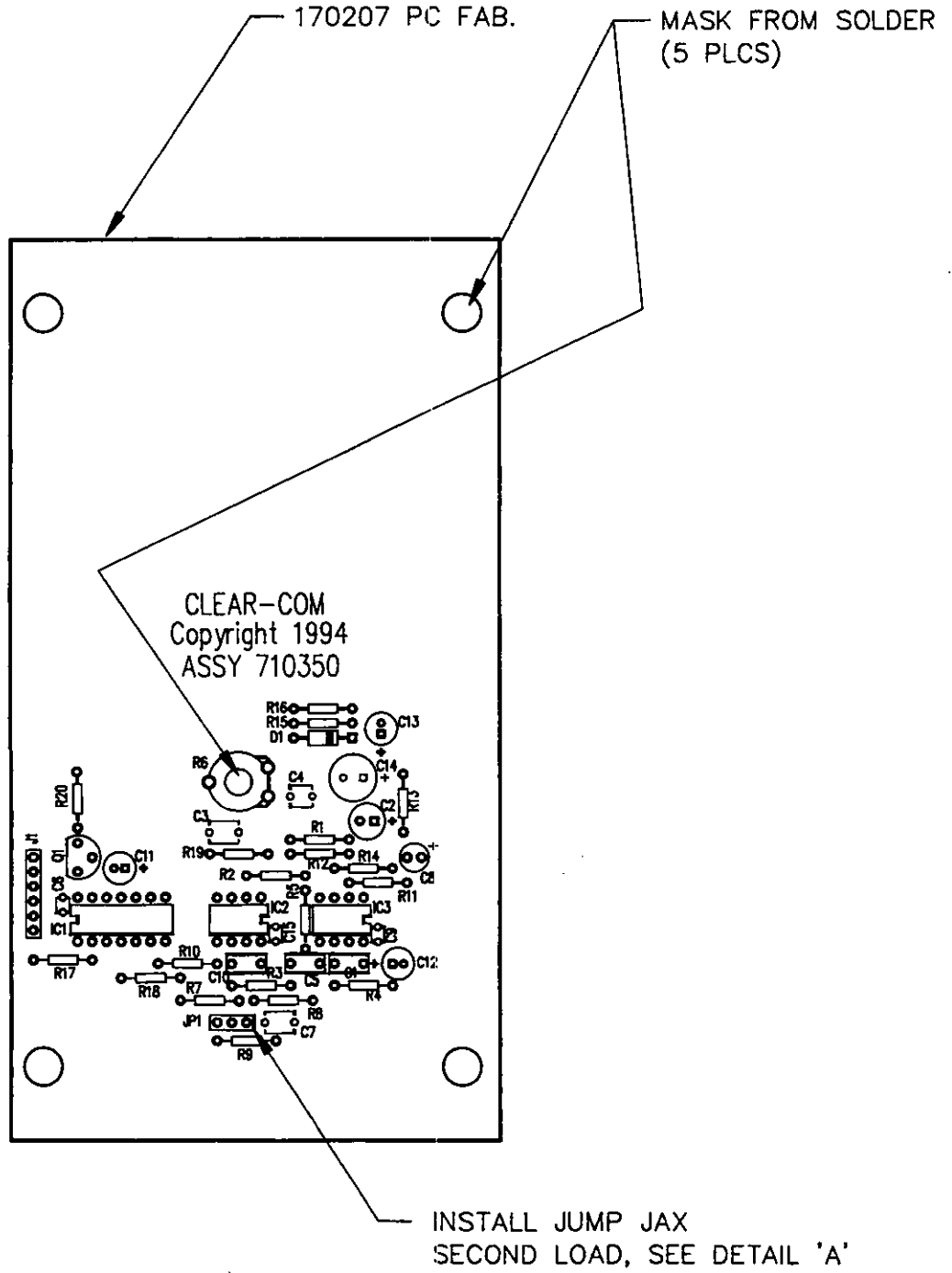

AB-100 Second Channel Option PCB Assembly Drawing

BILL OF MATERIALS FOR THE 2ND CHANNEL OPTION PCB ASY

Capacitors

| Value | Type | Type | Volts | Tol. | Part # | Designator |
|----------|-------------|------|-------|------|--------|------------|
| 39 PF | CERAMIC | | 50V | 5% | 150026 | C1,C10 |
| 200 PF | CERAMIC | | 100V | 5% | 150063 | C5 |
| .0022 UF | MYLAR | | 100V | 5% | 150045 | C4 |
| .047 UF | MYLAR | | 100V | 5% | 150131 | C3,C7 |
| .1 UF | MONOLITHIC | | 50V | 10% | 150035 | C6,C9,C15 |
| .47 UF | ALUMINUM | | 50V | | 150024 | C11,C12 |
| 1 UF | ALUMINUM NP | | 50V | 10% | 150002 | C8 |
| 4.7 UF | ALUMINUM NP | | 50V | | 150087 | C2 |
| 22 UF | ALUMINUM | | 35V | 20% | 150152 | IC13 |
| 220 UF | ALUMINUM | | 16V | 20% | 150146 | C14 |

Resistors

| Value | Power | Type | Tol. | Part # | Designator |
|------------|-------|-------------|------|--------|-----------------|
| 20.0K OHMS | 1/4W | METAL FILM | 1% | 410086 | R11,R12 |
| 26.1K OHMS | 1/4W | METAL FILM | 1% | 410192 | R3 |
| 47.5K OHMS | 1/8W | METAL FILM | 1% | 410105 | R2,R14 |
| 430 OHMS | 1/4W | CARBON FILM | 5% | 410106 | R13 |
| 2K OHMS | 1/4W | CARBON FILM | 5% | 410014 | R1 |
| 6.2K OHMS | 1/4W | CARBON FILM | 5% | 410137 | R8 |
| 10K OHMS | 1/4W | CARBON FILM | 5% | 410016 | R18 |
| 15K OHMS | 1/4W | CARBON FILM | 5% | 410017 | R9,R10 |
| 20K OHMS | 1/4W | CARBON FILM | 5% | 410151 | R5 |
| 22K OHMS | 1/4W | CARBON FILM | 5% | 410018 | R15,R16,R17,R20 |
| 100K OHMS | 1/4W | CARBON FILM | 5% | 410024 | R4 |
| 120K OHMS | 1/4W | CARBON FILM | 5% | 410079 | R7 |
| 390K OHMS | 1/4W | CARBON FILM | 5% | 410029 | R19 |

Integrated Circuits and Semiconductors

| Device | Description | Part # | Designator |
|-----------|--------------------------|--------|------------|
| DIODE | 1N4148 SIGNAL 10MA 75PIV | 480000 | D1 |
| I.C. | SSM-2402 DUAL SWITCH | 480208 | IC1 |
| OP-AMP | RC4559NB DUAL OP AMP | 480056 | IC2,IC3 |
| TRASISTOR | 2N2222 NPN 30V | 480006 | Q1 |

Mics. PCB Parts

| Device | Description | Part # | Designator |
|--------|----------------------------|--------|------------|
| JACK | JUMP JACK .1IN WITH HANDLE | 210226 | JP1 |
| POT | 5K TRIM POT H MTG. | 470022 | R6 |