

BTR-800 Wireless IC to Clear-Com PS-702 / PS-232 Party-line power supply

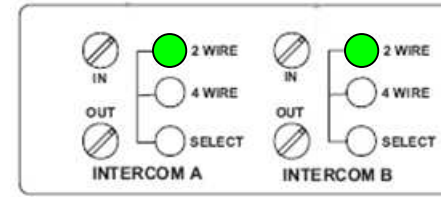
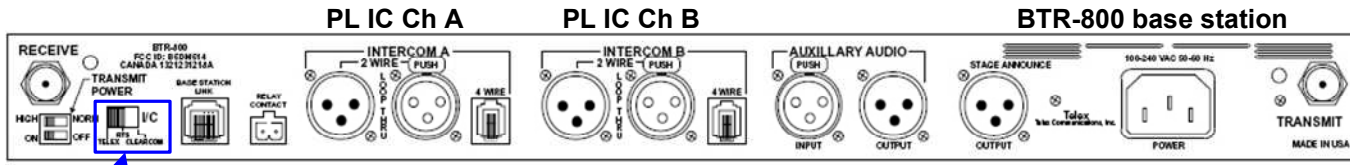

Set IC slide switch to "Clear-Com" mode

Set intercom "A" and "B" on front panel of BTR-800 to 2-wire mode using the select buttons (Green LED "on")

Balance intercom levels using the IN and OUT adjustment controls

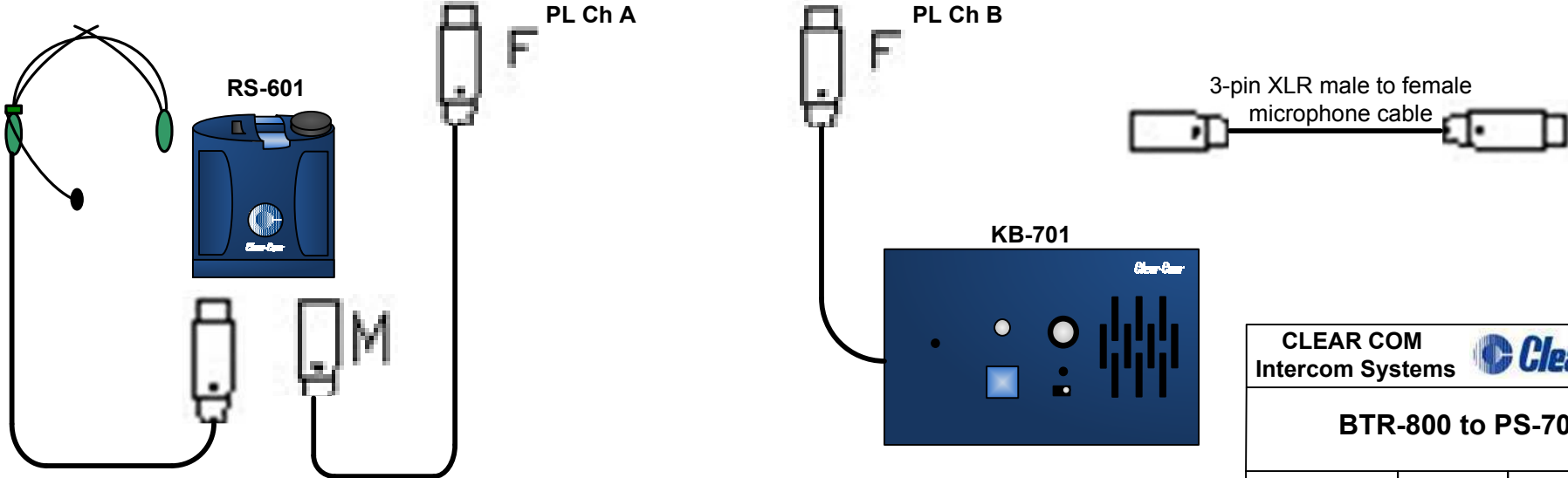
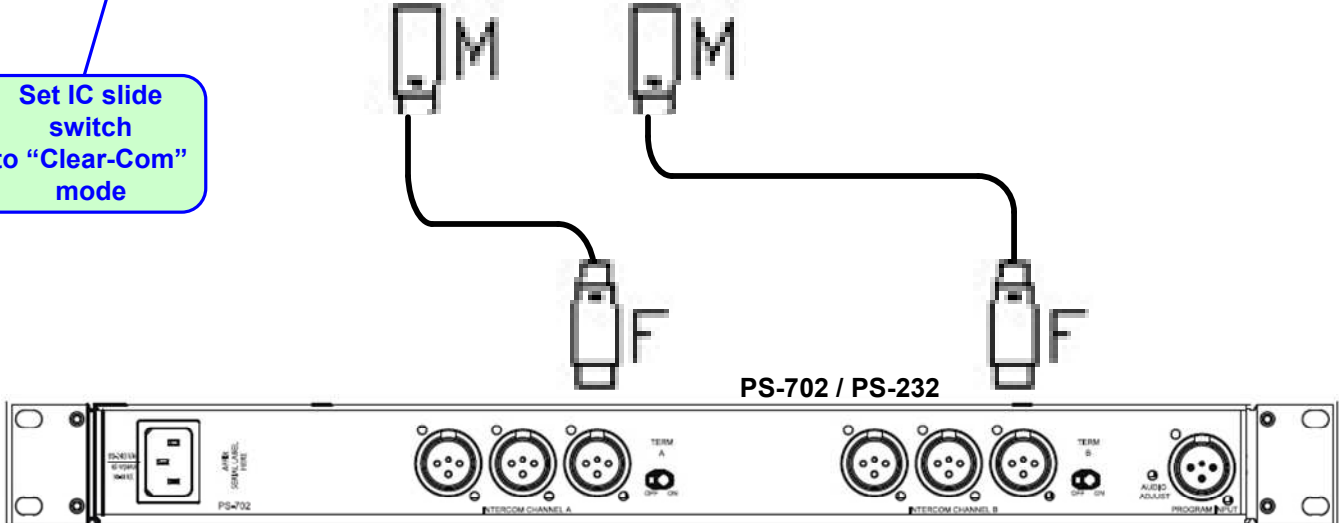

CLEAR COM Intercom Systems 

BTR-800 to PS-702